



USDA GUIDELINES

FOR THE SANITARY

DESIGN AND FABRICATION OF

DAIRY PROCESSING EQUIPMENT

June 2001

TABLE OF CONTENTS

A.	<u>USDA REVIEW PROCEDURES</u>	A - 1
B.	<u>SCOPE</u>	B - 1
	“Grandfathered” Equipment Exemption Policy	B - 2
C.	<u>DEFINITIONS</u>	C - 1
D.	<u>MATERIALS</u>	D - 1
E.	<u>FABRICATION</u>	E - 1
F.	<u>SPECIAL CONSIDERATIONS FOR PASTEURIZATION EQUIPMENT</u>	F - 1
G.	<u>SPECIAL CONSIDERATIONS FOR EXPOSED PRODUCT CONVEYORS</u>	G - 1
H.	<u>SPECIAL CONSIDERATIONS FOR CHEESE BRINE SYSTEMS AND RELATED EQUIPMENT</u>	H - 1
I.	<u>SPECIAL CONSIDERATIONS FOR CHEESE MOLDS</u>	I - 1
J.	<u>SPECIAL CONSIDERATIONS FOR MECHANICAL CLEANING SYSTEMS FOR LARGE EQUIPMENT OR VESSELS</u>	J - 1
K.	<u>SPECIAL CONSIDERATIONS FOR LACTOSE EQUIPMENT</u>	K - 1

A. USDA REVIEW PROCEDURES:

The following criteria, guidelines and principles set forth the sanitary design and fabrication features required by USDA, Dairy Grading Branch for the acceptance of equipment intended for use in dairy plants surveyed and approved for USDA grading service.

NOTE: If the equipment is also intended for use in the processing or packaging of meat and poultry products, review may also be necessary according to the criteria in the standard ANSI/NSF/3-A 14159-1-2000, Hygiene requirements for the design of meat and poultry processing equipment. You may contact our meat and poultry equipment review specialists at 202-720-8307.

The Dairy Grading Branch is a user fee supported service. Therefore, fees and expenses will be charged for the review of drawings or equipment, preparation of reports, travel and other expenses.

P.O. Box Address:
(U.S. Postal Service deliveries)

USDA/AMS/Dairy Division
Dairy Grading Branch
Room 2746-South Building
P.O. Box 96456
Washington, DC 20090-6456

Phone 202-720-3171

Fax 202-720-2643

Internet

www.ams.usda.gov/dairy/grade.htm

Street Address:
(Private mail service deliveries)

USDA/AMS/Dairy Division
Dairy Grading Branch
Room 2746-South Building
1400 Independence Ave., S.W.
Washington, DC 20250

E-mail

Rocklyn.Bates@usda.gov

Philip.Wolff@usda.gov

Dennis.Glick@usda.gov

Jeffrey.Wilson@usda.gov

Engineering drawings of the entire piece of equipment, with emphasis on product contact and exposed nonproduct contact surfaces, are generally required for evaluation of details for USDA acceptance. Engineering drawings must be of sufficient detail to clearly show:

- ★ dimensions of each part;
- ★ minimum radii dimensions of internal angles of less than 135 degrees;
- ★ product contact surface finish specifications;
- ★ specifications for welds and other permanent joints;

June, 2001

A - 1

- ★ design details for flanges, or gasketed joints which are to include enlarged drawing(s) (at least 2X) of the details of O-ring retaining grooves as appropriate;
- ★ dimensions of O-rings, gaskets, and any other type of seals; and
- ★ explanations of company symbols depicting welds and metal finishes.

Dimensions may be shown in either English or metric measurement terms. The required materials listings and terminology on the drawings should be in English or include translations into English. Concept or assembly drawings should also be provided as they are useful in showing the general configuration of the equipment and the relationship of component parts to each other.

Alternatively, the review can be performed on a finished piece of equipment on-site at either the equipment manufacturer or at a processing plant. The requirements for this type of review are:

- ★ Safe access must be provided;
- ★ All product contact surfaces must be clean and available for inspection;
- ★ Food and Drug Administration and 3-A Sanitary Standards certifications for all rubber and plastic materials should be available.

To initiate a sanitary design review, the prospective applicant may contact the Dairy Grading Branch by telephone, fax, e-mail, or mail. The **Equipment Review Request** form should be clearly marked in the appropriate box if the request is for an inspection within the United States or, if the design review will require travel to an inspection site outside of the United States. A copy of the form is included as part of these guidelines.

Applicants are advised that a minimum of 30-45 working days advance notice is required for any foreign travel and a minimum of 7 working days advance notice is required for domestic travel. Travel to inspection sites is based on a first-come-first-served basis and inspector availability. Applicants are encouraged to contact the Dairy Grading Branch, Washington, DC office to verify inspector availability and schedules prior to submitting a request for service.

U.S. DEPARTMENT OF AGRICULTURE
 AGRICULTURAL MARKETING SERVICE
 DAIRY PROGRAMS

EQUIPMENT REVIEW REQUEST

Applicant (Name and Address)	Party Responsible for Payment if other than Applicant (Name and Address) Confirmation Required (Letter or Fax) Received <input type="checkbox"/>	Equipment Located at (Name and Address)
Tax Identification No. (TIN) (new applicant only)	Tax Identification No. (TIN) (new applicant only)	Inspection Dates Requested
Contact	Contact	Contact
Telephone	Telephone	Telephone
Fax	Fax	Fax

Type of Equipment: Dairy
 Livestock or Poultry

Signature of Applicant	Date
------------------------	------

Domestic Inspection:
 A minimum of seven (7) working days notification is required to insure specialists have ample time to make arrangements for the trip. If specialists are unavailable, the next available date acceptable to all parties will be assigned.

Foreign Inspection:
 A minimum of thirty (30) working days advance notice is required for any foreign travel. The 30 days will start from the date this request form is received by the Dairy Grading Branch. If specialists are unavailable, the next available date acceptable to all parties will be assigned.

Hotel accommodations (USDA Dairy must pay): _____ Best mode of transportation from airport (train, taxi, company pick up ...): _____
 Does the Hotel accept Visa credit cards: Yes No

Mail or Fax this form to the appropriate address below:

Dairy Equipment Review Address: USDA/AMS/DAIRY PROGRAMS Dairy Grading Branch Design Review Section Room 2746 - South Building P.O. Box 96456 Washington, DC 20090-6456 Tel: 202 720-3171 Fax: 202 720-2643	Livestock and Poultry Equipment Review Address: USDA/AMS/DAIRY PROGRAMS Dairy Grading Branch Design Review Section Room 612 - Cotton Annex P.O. Box 96456 Washington, DC 20090-6456 Tel: 202 720-8307 Fax: 202 720-8581
--	---

FOR OFFICIAL USE ONLY:

Date Received: _____ Specialist Assigned: _____
 Date Assigned: _____ Project Number(s): _____

B. SCOPE:

Dairy Grading Branch policy fully supports and utilizes established 3-A Sanitary Standards and Accepted Practices. Copies of the 3-A Sanitary Standards and 3-A Accepted Practices can be obtained from:

Techstreet
1327 Jones Drive
Ann Arbor, MI 48105

Telephone: 800-699-9277 (United States and Canada)
734-302-7801 (All other locations)

Fax: 734-302-7811

Web Address: www.techstreet.com/3Agate.html
or
www.techstreet.com/contact.html

3-A Sanitary Standards provide criteria for materials and fabrication for specific types of dairy equipment. Examples of equipment covered by 3-A Sanitary Standards are centrifugal and positive displacement rotary pumps, compression valves, non-coil batch processors, and bag collectors for dry milk products. 3-A Accepted Practices establish criteria for the materials, fabrication, and installation of processing systems which employ component pieces of equipment, many of which are covered by 3-A Sanitary Standards. Examples of 3-A Accepted Practices are spray drying systems, HTST pasteurizer systems, and culinary steam producing systems.

When equipment is presented to USDA for review for which a 3-A Sanitary Standard or 3-A Accepted Practice has been developed or which applies, USDA will use those standards as the evaluation criteria.

USDA does not require that equipment which is authorized to bear the 3-A Symbol to be additionally presented to USDA for review. Equipment bearing a 3-A Symbol will normally be accepted by Dairy Grading Branch inspectors and be subjected to routine plant survey evaluation for sanitation. However, if the routine inspection reveals deficiencies with materials, design, fabrication, or workmanship, which appear to violate the applicable 3-A Sanitary Standards, USDA will request the fabricator to make appropriate modifications. USDA also will file a "Complaint of Alleged Non-Compliance" with the 3-A Symbol Council.

June, 2001

B - 1

Equipment manufacturers may optionally request a USDA-Dairy Grading Branch review to eliminate or minimize the likelihood of such complaints. Such a review and acceptance will allow a positive response to inquiries from potential customers about the USDA-Dairy Grading Branch position on the acceptability of the equipment for use in dairy plants surveyed and approved for USDA dairy grading service.

Equipment buyers are encouraged to require USDA-Dairy Grading Branch acceptance for equipment as a provision of a purchase contract. The requirement should be clearly written so as not to confuse USDA-Dairy acceptance with compliance with other requirements, such as 3-A Sanitary Standards, Dairy Grading Branch evaluation and acceptance of processing equipment used in the meat and poultry industries, or requirements of other Federal or State Agencies. Equipment accepted or approved by the discontinued USDA, Food Safety and Inspection Service (FSIS); or, independently run State review services does not confer acceptance by the Dairy Grading Branch, USDA.

When a USDA-Dairy Grading Branch review is requested of equipment for which there are no 3-A Sanitary Standards or Accepted Practices, USDA will use the general criteria, guidelines, and principles outlined in this document. These criteria, guidelines, and principles are consistent with those utilized by the 3-A Sanitary Standards Committees during the development of standards and accepted practices. Sections C, D, and E shall apply unless modified by a subsequent "Special Consideration" section.

“Grandfathered” Equipment Exemption Policy

Occasionally, the USDA will use a "grandfather" exemption for plant equipment. A "grandfather" exemption, as it pertains to equipment and plant inspection activities, is the procedure by which an inspection agency, such as the Dairy Grading Branch, can accomplish the orderly, phased removal or replacement of equipment which has become obsolete due to advances in equipment design or processing techniques. This procedure allows the processor to continue using a piece of equipment which, when installed, complied with all existing requirements but which no longer complies with current standards or requirements.

A "grandfather" exemption does not sanction improper sanitation or poor maintenance of equipment. All "grandfather" exempted equipment will eventually wear out or may reach a stage of disrepair such that it can no longer be accepted. At that time, the equipment is to be treated as any other piece of equipment in similar condition and it should be repaired or replaced.

A "grandfather" exemption, as it is used by the Dairy Grading Branch, is specific to the equipment or plant location and may assume two slightly different applications depending upon the circumstances encountered.

June, 2001

B - 2

Application I:

The policy is specific to a class or model of equipment which may be located at a number of different locations. The "grandfather" exemption status may be assigned to a particular model because of the lack of available alternatives or long standing use. An example of this approach would be the use of Mor-Pac butter printing machines which are commonly used throughout the butter industry even though alternative machines are also available.

Application II:

The policy is specific to an identified machine located at an identified processing facility. For example, a rotary airlock which does not meet current design criteria could be granted a "grandfather" exemption as a part of a drying system at an identified drying plant.

Although the "grandfather" exemption is intended to accomplish the phased withdrawal or replacement of the equipment. The time frame during which a "grandfather" exemption remains in effect can be quite long. There is no mandatory maximum time period restriction. However, the Dairy Grading Branch may announce the end of a "grandfather" exemption following notification to the industry and provision of a specific phase out period to accomplish replacement of the equipment.

Under Application I, the "grandfather" exempted item may move freely between locations until such time that the particular unit is no longer acceptable due to disrepair. Should an acceptable alternative be developed and become readily available, the Dairy Grading Branch will determine when all of the remaining items would revert to an Application II status.

Under Application II, the "grandfather" exempted item is a specific model located at a specific processing facility. The item is not free to move between locations. Processing facilities utilizing equipment exempted by this application shall not be eligible for the FULL STATUS rating. Lesser status assignments may be made consistent with plant conditions and sanitation. If the item is moved from the identified processing facility to another approved facility, the item shall be upgraded to meet all current standards, requirements and regulations.

In addition under Application II, if the processing facility should withdraw from the Dairy Grading Branch plant survey program for an extended period of time equal to or exceeding one year, all "grandfather" exempted equipment shall be upgraded to current standards, requirement or regulations in order for the facility to be reinstated as an approved facility. Withdrawal from the plant survey program is not interpreted to include temporary losses of approved status during which the processing facility is actively working to regain approval.

June, 2001

B - 3

When an approved processing facility which includes some equipment accepted by "grandfather" exemptions constructs new facilities, the following criteria will apply:

- 1. The new facility is an expansion or remodeling of an existing building, or a new building at the same site.**

All "grandfather" exemptions granted under Application I and II are permitted to be used in the new facility.

- 2. The new facility is at a new site separate from the original facility. (i.e., across town, in another town, a mile down the road, etc.)**

Equipment granted a "grandfather" exemption under Application I is permitted to be used in the new facility. Equipment granted a "grandfather" exemption under Application II is not permitted to be moved to the new facility without upgrading to current standards, requirements and regulations.

A change in ownership of a processing facility which does not interrupt the cycle of unannounced plant surveys would not alter the "grandfather" exemption status of items at that facility.

The U.S. Department of Agriculture (USDA) prohibits discrimination in all its programs and activities on the basis of race, color, national origin, sex, religion, age, disability, political beliefs, sexual orientation, or marital or family status. (Not all prohibited bases apply to all programs.) Persons with disabilities who require alternative means for communication of program information (braille, large print, audiotape, etc.) should contact USDA's TARGET Center at 202-720-2600 (voice and TDD).

To file a complaint of discrimination, write USDA, Director, Office of Civil Rights, Room 326-W, Whitten Building, 14th and Independence Avenue, SW, Washington, DC 20250-9410, or call (202) 720-5964 (voice and TDD). USDA is an equal opportunity provider and employer.

June, 2001

B - 4

C. **DEFINITIONS:**

1. **Product:** Shall mean any milk, milk product, related product, or fraction thereof which is to be processed or packaged by the equipment.
2. **Product Contact Surface:** Shall mean all surfaces;
 - a. Exposed to the product, or
 - b. Exposed to the surfaces of the packaging materials which touch the product, or
 - c. That touch the surfaces of the packaging materials which touch the product, or
 - d. From which liquids or other materials may drain, drop, diffuse or be drawn into the product, or
 - e. From which liquids or other materials may drain, drop, diffuse or be drawn onto the surfaces that touch or are exposed to the surfaces of the packaging materials which touch the product.

Note: The product contact surfaces of exposed product conveyors and packaging equipment may be isolated by sanitary shielding or other acceptable means of clear demarcation. (See Section G, Special Consideration for Exposed Product Conveyors)

3. **Splash Contact Surface:** Shall mean a nonproduct contact surface that during normal use is subject to accumulations of soil and which require routine cleaning.
4. **Processing Air Contact Surface (for Air to be Heated or Air not to be Heated):** Shall mean all surfaces in contact with filtered air prior to coming in contact with the product, commencing at the frame of the final inlet air filter(s) and ending at the first downstream product contact surface.
5. **Exhaust Air Contact Surface:** Shall mean the surfaces of air ducts, plenums, or other appurtenances commencing at the end of the product contact surface and ending at the discharge point of air from the equipment or system.
6. **Non-product Contact Surface:** Shall mean all other exposed surfaces.

7. **R_a Value:** Shall mean the average roughness value of a surface as measured according to procedures and using terms found in American National Standard, AMSE/ANSI B46.1 1985, Surface Texture, (Surface Roughness, Waviness, and Lag) or ISO Standard, ISO 4287/1, Surface Roughness - Terminology - Part I; Surface and Its Parameters.

8. **Surface Treatment:** Shall mean a process whereby chemical compositions or mechanical properties of the existing surface are altered and there is no appreciable build-up (less than 1 micrometer) of new material. Surface treatments may include;
 - a. Mechanical (shot peening, glass beading, polishing).
 - b. Thermal (surface hardening laser, electron beam).
 - c. Diffusion (carbonizing, nitriding).
 - d. Chemical (etching, oxidation).
 - e. Ion Implantation.
 - f. Electropolishing.

9. **Surface Coating:** Shall mean the results of a process whereby a different material is deposited upon a surface to create a new surface with altered functional characteristics and there is an appreciable build-up (greater than 1 micrometer) of new material. Surface coating may include;
 - a. Chemical (conversion coatings).
 - b. Engineering Plating. (e.g., electrodeposition, gold).
 - c. Thermal Spraying (e.g., flame, plasma, arc spraying).
 - d. Physical Vapor Deposition.
 - e. Chemical Vapor Deposition.
 - f. Overlays and Encapsulation.

10. **Manual (COP) Cleaning:** Shall mean the cleaning of all product contact surfaces by complete disassembly and manual brushing and/or application of cleaning solutions. When this method of cleaning is required, the equipment design shall provide for easy disassembly with the use of simple hand tools commonly available to plant production or sanitation employees.
11. **Mechanical Cleaning or Mechanically Cleaned:** Shall mean the cleaning of product contact surfaces by impingement, circulation, or flowing cleaning solutions and water rinses onto and over the surfaces to be cleaned by mechanical means in equipment specifically designed for this purpose.

Note: The terminology "CIP" or "Cleaned in Place" is reserved for the cleaning of welded pipeline systems and silo tanks only.
12. **Bond:** The adhesive materials or cohesive forces holding components together. This definition excludes press and shrink fits.
13. **Easily or Readily Removable:** Shall mean quickly separated from the equipment with the use of simple hand tools if necessary.
14. **Easily or Readily Accessible:** Shall mean so located as to be safely reached by personnel from the floor, other permanent work area, or a platform.
15. **Inspectable:** Shall mean an item or area can be made available or exposed for close visual observation.
16. **Simple Hand Tools:** Shall mean implements or utensils, such as a screwdriver, wrench, or mallet, normally used by operating and cleaning personnel.
17. **Dead End or Space:** Shall mean an area or space in which product, cleaning solution, or sanitizing solution, or other matter may become trapped, held, or not completely removed during product operational or cleaning procedures. (The evaluation of dead ends for large diameter piping or ducts will be evaluated on a case by case basis.)
18. **Substantially Flush:** Shall mean mating surfaces or other associated surfaces, such as gaskets, shall be within 1/32 in.
19. **Close Coupled:** Shall mean mating surfaces or other associated surfaces, such as a valve seat, are less than twice the nominal diameter or cross section of the mating surfaces but no greater than 5 inches from the mating surface.

D. MATERIALS:

1. **Stainless Steel:** Shall be of the AISI 300 series or corresponding ACI types or stainless steel that is non-toxic and non-absorbent and which under conditions of intended use is equal in corrosion resistance to stainless steel of the AISI 300 series (excluding types 301 and 302) or corresponding ACI types; or, other metal which under the conditions of intended use is at least as corrosion resistant as the forgoing types, and is non-toxic and non-absorbent.

The data for AISI 300 series are contained in the AISI Steel Products Manual, Stainless & Heat Resisting Steels, December 1974, Table 2-1, pp. 18-20. Available from the Iron and Steel Society, 410 Commonwealth Drive, Warrendale, PA 15086 (412-776-9460).

The data for ACI types are available from the Alloy Casting Institute Division, Steel Founders Society of America, Cast Metal Fabrication Bldg., 455 State St., Des Plaines, IL 60016 (708-299-9160).

AISI 400 series may be used for specified applications such as cutting blades and associated parts when hardening characteristics are required.

2. **Aluminum:** Aluminum is satisfactory for certain butter and dry products applications. Aluminum may be used for liquid or high moisture content product contact surfaces only when a specific functional requirement exists and the parts are not subjected to strong caustic cleaning solutions or to the corrosive action of dissimilar metals.

The aluminum type chosen for the application shall be demonstrated to be appropriate and acceptable for the intended use. (Provisions have been made in existing 3-A Standards for Aluminum Association designations 5052, 6061, 6063, A-360, A-380, A-319, A-315G, and C-413, Danish Standards DS #3002 and #4261, and ASTM standards B179, and S12c for certain specified uses.)

3. **Other Corrosion Resistant Metals:** Other corrosion resistant metals or alloys that are non-toxic under conditions of intended use may be used when their properties are required for functional reasons. The metal alloys shown in the following table are examples considered to be acceptable. Percentages are maximum unless a range is provided. Other alloys may be acceptable and will be evaluated on a case by case basis. This may be shown when the alloys are tested in accordance with ASTM G31 Laboratory Immersion Corrosion Testing of Metals and have a corrosion rate of less than 10 mil per year. The test parameters such as the type of chemical(s), their concentration(s), and temperature(s) should be representative of cleaning and sanitizing

conditions used in dairy equipment. Alloys containing lead, leachable copper, or other toxic metals shall not be used.

	UNS N08367	UNS S21800	UNS S20161	UNS N26055	UNS N26455	UNS S17400	UNS S15500	UNS S32900	UNS R20500	UNS R50400
	ASTM A743 Grade	ASTM A743 Grade		ASTM A494 Grade	ASTM A494 Grade	ASTM A747 Grade	ASTM A747 Grade		ASTM A560 Grade	ASTM B67 Grade
	CN-3MN	CF-10 SMnN		CY5SnBiM	CW-2M	CB7Cu-1	CB7Cu-2		50Cr50Ni	C-2
C	0.03	0.10	0.15	0.05	0.02	0.07	0.07	0.20	0.10	0.10
Mn	2.00	7.00-9.00	4.00-6.00	1.5	1.00	0.70	0.70	1.00	0.30	
Si	1.00	3.50-4.50	3.00-4.00	0.5	0.80	1.00	1.00	0.75	1.00	
P	0.040	0.040	0.040	0.03	0.03	0.035	0.035	0.040	0.02	
S	0.010	0.030	0.040	0.03	0.03	0.03	0.03	0.030	0.02	
Cr	20.0-22.0	16.00-18.00	15.0-18.0	11.0-14.0	15.0-17.5	5.50-17.7	14.0-15.50	23.0-28.0	48.0-52.0	
Ni	23.5-25.5	8.00-9.00	4.00-6.00	Balance	Balance	3.60-4.60	4.50-5.50	2.50-5.00	Balance	
Mo	6.0-7.0			2.0-3.5	15.0-17.5			1.00-2.00		
Cb						0.15-0.35	0.15-0.35			
Cu	0.75					2.50-3.20	2.50-3.20			
N	0.18-0.26	0.08-0.18	0.08-0.20			0.05	0.05		0.30	
Fe	Balance	Balance	Balance	2.00	2.00	Balance	Balance	Balance	1.00	0.30
Sn				3.0-5.0						
Bi				3.0-5.0						
W					1.0					
Ti									0.50	
Al									0.25	Balance
Other										H=0.015 N=0.03 O=0.25

4. **Brass or Bronze:** These materials are not acceptable for product contact surfaces; or, bearing surfaces or exposed surfaces or fittings for air, hydraulics, or vacuum systems, which are in close proximity to product contact surfaces and which may be subject to cleaning solutions.

Brass or bronze fittings used as referenced above and which are located in nonproduct contact surfaces complying with Item E 43 are acceptable.

5. **Plastic Materials:** Shall comply with the applicable Food and Drug Administration regulations (21 CFR Parts 170 to 199) and also with the "3-A Sanitary Standards for Multiple-Use Plastic Materials Used as Product Contact Surfaces For Dairy Equipment." The tests may be performed and certification provided by the plastic manufacturer, the buyer, or by a commercial laboratory. (See Item E 8).

FDA regulations 21 CFR parts 170 to 199 are available from the Superintendent of Documents, U.S. Government Printing Office, Washington, DC 20402. Telephone 202-783-3238. Payment may be made by check or money order. Orders are also accepted using Master Card, Visa, or Choice credit cards by telephone or over the internet at www.access.gpo/#info.

6. **Rubber Materials (Flexible, soft-type):** Shall comply with the applicable Food and Drug Administration regulations (21 CFR Part 177.2600) and also with the most current "3-A Sanitary Standards for Multiple-Use Rubber and Rubber-Like Materials Used as Product Contact Surfaces in Dairy Equipment." The tests may be performed and certification provided by the rubber manufacturer, the buyer, or by a commercial laboratory. (See Item E 8).
7. **Adhesives:** Shall be non-toxic and comply with the applicable Food and Drug Administration regulations (21 CFR 175). See Item D 5 above for CFR purchasing instructions. (See Item E 8).
8. **Carbon, Ceramics, Silicon Carbide, or Tungsten Carbide:** Shall be inert, non-porous, non-toxic, non-absorbent, insoluble, and resistant to scratching, scoring, and distortion when exposed to the conditions encountered in the environment of intended use and in cleaning and bactericidal treatment.
9. **Silver Bearing Solder or Brazing Material:** Shall be corrosion-resistant; free of cadmium, lead and antimony; non-absorbent; and shall not impart any toxic substance to the product when exposed to the conditions encountered in the environment of intended use and in cleaning and bactericidal treatment or sterilization.

10. **Materials Used for Surface Treatments and Coatings:** All materials and components used for surface treatments and coatings and residues remaining on product contact surfaces shall be documented to show they comply with the appropriate provisions of the following:

- a. FDA regulations 21 CFR 175, Subpart C - Substances for Use as Components of Coatings, or
- b. FDA regulations 21 CFR 177, Subpart B - Substances for Use as Basic Components of Single and Repeated Use Food Contact Surfaces, or
- c. FDA regulations 21 CFR 177, Subpart C - Substances for Use Only as Components of Articles Intended for Repeated Use, or

d. Nickel:

QQ-N-290a- Federal Specification for Nickel Plating Electrodeposited) November 12, 1971. Both documents available from the General Services Administration, 18th & F Sts., NW, WFCIA, Washington, DC 20405 (202-472-2205), or

MIL-C-26074C- 3 May 1985 Military Specification; Coatings, Electroless Nickel, Requirements for; as amended by Notice one, 14 May 1971. Superintendent of Documents, U.S. Printing Office, Washington, DC 20402 (202-783-3238), or

e. Rubber and Rubber-Like materials:

Shall additionally comply with the provisions of preceding Item D 6 of these guidelines, or

f. Plastic materials:

Shall additionally comply with the provisions of preceding Item D 5 of these guidelines.

11. **Glass:** Shall be restricted to uses where there is a demonstrated function need for glass and shall be of a clear, heat resistant, shatter-resistant type.

12. **Woven Cotton, Linen, Silk, or Man-made Fibers:** Shall be used only for dry products flexible connectors and for certain filtering, sifting and screening applications. These materials may optionally be covered by a synthetic membrane laminate. These materials shall be nontoxic, relatively insoluble in water, easily cleanable, shall not peel or delaminate, shall not impart particulate material or flavor to the product. Man-made fibers and synthetic laminate materials shall meet the appropriate criteria in the Code of Regulations, 21 CFR 170-199, or be otherwise accepted by the Food and Drug Administration for repeated food contact.
13. **Caulking Materials, including silicone, silastic, or stainless steel epoxy types:** May be used to seal pockets or crevices on exterior, nonproduct contact surfaces.

These materials are not acceptable for use on product contact surfaces, except as an adhesive for bonded gaskets.
14. **Paint:** Shall be limited to the coating of nonproduct contact surfaces. Parts which have both a product contact surface and nonproduct contact surface and are subject to washing shall not be painted.
15. **Lubricants:** As provided by FDA regulations, lubricants which have incidental food contact shall be limited to those specified in 21 CFR Part 178.3570. The amount used shall be the minimum required for the desired technical effect on the equipment and shall not exceed any prescribed limitations. Example: Light coating of mineral oil on chill rolls to prevent sticking of process cheese.
16. **Other Materials:** Other materials having certain inherent functional properties which are proposed to be used for specific product contact applications shall be submitted for USDA review and evaluation for each application.
 1. Oil impregnated plastics for use as bushings or bearings.

E. FABRICATION:

1. All product contact surfaces shall have a finish at least as smooth as a number 4 ground finish on stainless steel sheets, free of pits, cracks, folds, and other imperfections in the final fabricated form. The surface finish obtained by 150 grit silicon carbide **properly applied** to stainless steel sheets is considered as equivalent to the number 4 finish. A maximum R_a of 32 microinch (0.8 micron) is considered to be equivalent to a No. 4 finish.

The 2B mill finish on stainless steel sheets is also considered as smooth or smoother than a polished number 4 finish. No further finishing is required if the 2B finish is free of defects, such as pits, scratches, chips, or flakes, in the final fabricated form. (Use of adhesive protective paper is recommended during equipment fabrication to prevent or minimize damage to stainless steel finishes.)

Note: The 2B finish on stainless steel plate and bars is usually not as smooth as the number 4 finish on sheets due to less cold rolling and therefore unacceptable for product contact surfaces without additional surface preparation.

Mechanical surface treatment by shot peening or glass beading of product contact surfaces is acceptable provided the treatment serves a specific functional purpose, i.e., in order to prevent product sticking on butter and mozzarella cheese equipment. The surface which is to be treated must be either a 2B mill finish or have been prepared to the equivalent of the number 4 finish.

Electropolishing, glass beading or shot peening surface treatments are not acceptable alternatives to the required grinding and polishing of welded junctures to a number 4 finish. Surfaces are to be properly prepared prior to the application of these treatments.

2. The minimum thickness of electrodeposited coatings on product contact surfaces shall be not less than 0.0002 inches (0.005mm) and shall not crack, craze, chip, or spall.
3. Cast metal coatings used as product contact surfaces shall be at least 0.040 inch (1.0mm) thick and shall not crack, craze, chip, or spall.

4. Ceramic materials used as coatings for product contact surfaces shall be at least 0.003 inch (0.08mm) thick and shall not crack, craze, chip, or spall.
5. Permanent joints for product contact surfaces (not intended for disassembly for cleaning) shall be designed so they are fully cleanable when assembled. See Item E.11 regarding radii requirements. The following are acceptable methods of fabrication:
 - a. Continuously welded, ground, and polished to a number 4 finish which is free of pits, folds, crevices or projections, except that;

Welds in aluminum product contact surfaces shall be free of pits, folds and crevices using the Gas Metal-Arc Welding (GMAW) process with backing bar, the Gas Tungsten-Arc Welding (GTAW) process, the combination of GMAW and GTAW, or equivalent process. The completed weld shall be lightly finished with a stainless steel wire brush, resulting in maximum weld surface irregularity of twelve thousandth of an inch (0.03mm) differential within 1/8 in. (3mm) increments. The maximum weld height shall be 1/8 in. (3mm).

- b. Properly constructed gasketed junctures. Flanged junctures shall be mated accurately and be constructed so the sealing edges of the flanges are not chamfered or radiused. The juncture shall create a tight pinch seal with the gasket. Interior surfaces shall be substantially flush, with no recesses or protruding unsupported gasket material.

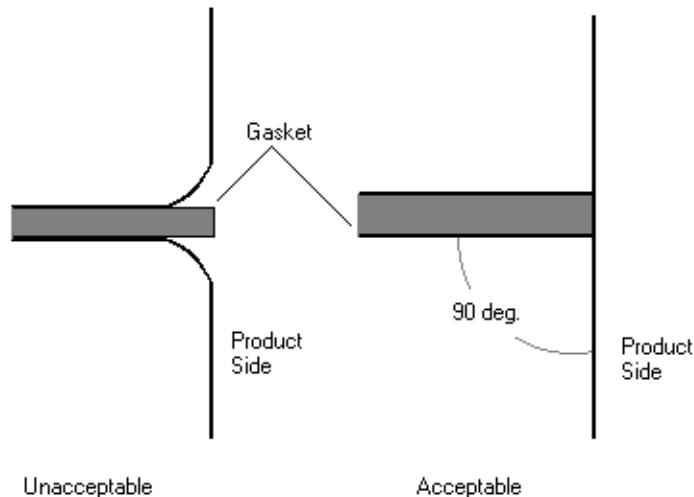

- c. Silver soldered, brazed, or vacuum brazed.

June 2001

E - 2

- d. Press fits or shrink fits may be used to produce crevice free permanent joint in product contact surfaces when welding is not practical. Joints of these types may only be used to assemble parts having circular cross sections free of shoulders, chamfers, or relieved areas, or knurled surfaces. For example: they may be used to assemble round pins or round bushings into round holes. In both types of fit, the outside diameter of the part being inserted is greater than the inside diameter of the hole.

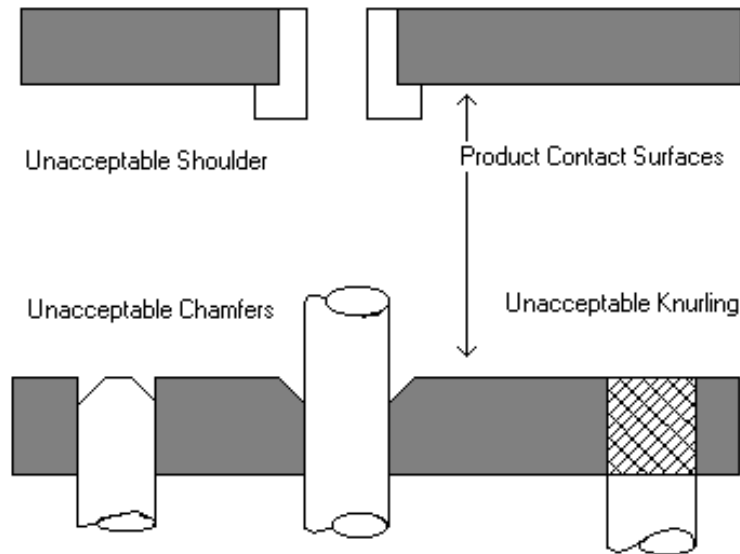

In the case of the press fit, the parts are forced together by applying pressure. The pressure required is dependent upon the diameter of the parts, the amount of interference and the distance the inner part is forced into the outer part.

In the case of a shrink fit, the diameter of the inner part is reduced by chilling to a low temperature. Dry ice is commonly used to shrink the inner part. Alternatively, shrink fits are made by heating the outer part. Less assembly force is required for this type of fit.

The design of these fits depends on a variety of factors. The designer should follow recommended practices to assure that a crevice-free joint is produced. A recognized authoritative reference is "Machinery's Handbook" published by Industrial Press, Inc., 200 Madison Ave., New York, NY 10157.

6. Nonpermanent junctures which are intended for disassembly and manual cleaning may be appropriately gasketed, when necessary. Nongasketed junctures are acceptable in certain applications which will be evaluated on a case by case basis. The junctures shall be constructed so they are readily accessible and easily removable.

Wing, "T", or palm nut style fasteners are preferred over hex or dome nuts to facilitate dismantling for cleaning or inspection.

Exceptions may be made, on a case by case basis, for instances when conventional bolting may be required for pressure, vacuum, or safety conditions.

7. Tubing used to convey product shall be stainless steel, except that flexible rubber or plastic tubing may be used for the following applications:

- a. Loading or unloading of movable tanks, vessels, or trucks.
- b. Temporary hookups while equipment or permanent piping is being installed.
- c. The prevention of vibration transmission.
- d. Applications where it is important to see the product flow.
- e. Short jumpers for connecting equipment to CIP circuits.
- f. Permeate handling on some membrane systems.
- g. Short jumpers required in conveying product for mechanically moving parts.

When flexible tubing is slipped over a pipe stub and fastened with a clamp, the clamp shall be readily removable and the pipe stub shall be removed from the hoses for daily manual cleaning. Worm screw type clamps (radiator hose type clamps) are unacceptable. An alternative is to have the flexible hose fastened permanently to the stainless steel or acceptable plastic pipe fitting by special vulcanization, molding, bonding or by mechanical swaging to special fittings.

For requirements for Hose Assemblies refer to 3-A Sanitary Standards for Hose Assemblies for Milk and Milk products, Number 62-.

8. When plastic, rubber or rubber-like materials and adhesives are used as product contact surfaces, certification that the materials comply with the requirements of materials items D 5 and D 6 shall be provided to USDA.

All certifications shall be on company letterhead paper and include the following information:

- a. Material trade name or type.
- b. Declaration of compliance with the appropriate 3-A Sanitary Standards.
- c. Declaration of compliance with the appropriate, specific Food and Drug Administration CFR citation (such as 21 CFR 175.105, 21 CFR 177.2600 or 21 CFR 177.1580).
- d. Results of test data, (at the option of USDA).
- e. Signature of a responsible certifying official.

9. There shall be no exposed threads on product contact surfaces except as may be provided for by a special consideration section of these guidelines, or where required for safety or functional reasons. Where necessary for safety or functional reasons the threads shall conform to the dimensions of the coarse American Standard Stub Acme Thread (Brass Valve Stem Thread), the General Purpose Acme Thread, or other similar coarse thread design accepted by the Dairy Grading Branch.

**AMERICAN STANDARD STUB ACME THREAD
(BRASS VALVE STEM THREAD)**

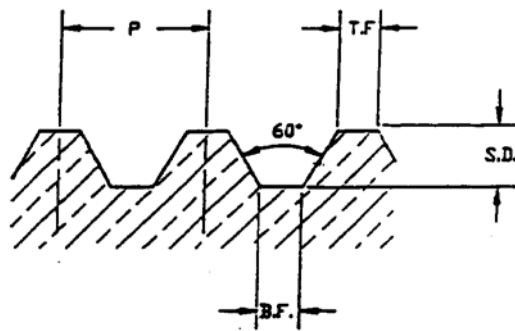

P = PITCH	$P = \frac{1}{T.P.I.}$
S.D. = SINGLE DEPTH	S.D. = .381 X P
T.F. = TOP FLAT	T.F. = .280 X P
B.F. = BOTTOM FLAT	B.F. = .280 X P
T.P.I. = THREADS PER INCH	

GENERAL PURPOSE ACME THREAD

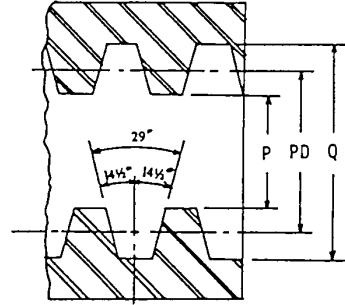
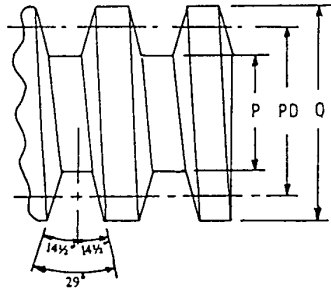

THREAD DIMENSIONS

EXTERNAL THREAD

SIZE	ACME THDS PER IN	P	Q	PITCH DIA	TOLERANCE P,Q & P.D.
1	8	1.317	1.462	1.3995	+0.000 -0.018
1 1/2	8	1.849	1.994	1.9315	+0.000 -0.019
2	8	2.381	2.526	2.4635	+0.000 -0.020
2 1/2	8	2.913	3.058	2.9955	+0.000 -0.021
3	8	3.445	3.590	3.5275	+0.000 -0.022
4	6	4.509	4.695	4.6120	+0.000 -0.025

INTERNAL THREAD

SIZE	ACME THDS PER IN	P	Q	PITCH DIA	TOLERANCE P,Q & P.D.
1	8	1.317	1.462	1.3995	+0.000 -0.018
1 1/2	8	1.849	1.994	1.9315	+0.000 -0.019
2	8	2.381	2.526	2.4635	+0.000 -0.020
2 1/2	8	2.913	3.058	2.9955	+0.000 -0.021
3	8	3.445	3.590	3.5275	+0.000 -0.022
4	6	4.509	4.695	4.6120	+0.000 -0.025

10. Coil springs having product contact surfaces shall have openings between the coils of at least 3/32 inch (2mm) including the ends, when the spring is in a relaxed condition. Coil springs shall not have the end coils ground flat creating a hard to clean crevice condition.
11. All internal angles of less than 135 degrees on product contact surfaces shall have at least a 1/4 inch (6mm) radius except:
 - a. Fillets of welds where one or both of the pieces being joined are 3/16 of an inch (5mm) thick or less, in which case the radius shall be not less than 1/8 inch (3mm).

- b. Where necessary for functional reasons, such as intricately machined parts, in which case the radius shall not be less than 1/32 inch (0.8mm). When radii less than 1/32 inch (0.8mm) are needed, they will be approved on a case by case basis and the product contact surfaces shall be readily accessible and inspectible.
- c. where necessary because the radii has an adverse effect on the dairy product, such as, curd cutting knives or cheese hoops. When radii less than 1/32 inch (0.8mm) are needed, they will be approved on a case by case basis and the product contact surfaces shall be readily accessible and inspectible.
- 4. The radius at the intersection of press-fits, shrink-fits, and flat sealing surfaces is zero by nature of the design and definition of this type of fabrication.
- e. Internal angles of less than 135 degrees formed by bending shall have at least a 1/4 inch (6mm) radius unless required for essential functional reasons, such as seal retainer parts. In no case shall such radii be less than 1/32 inch (0.8mm).
- f. Internal angles of gasket retaining grooves for gaskets shall be not less than 1/8 inch (3mm), except for gasket retaining grooves for bonded gaskets and for standard 1/4 inch (6mm) cross section and smaller O-ring grooves. See item g below.
- g. The internal angles of retaining grooves for standard O-rings shall have minimum radii per the following table:

O-Ring Cross Section			Minimum Groove Radius	
AS 568 (Inch)		ISO 3601-1 (mm)		
Nominal	Actual	Actual	(Inch)	(mm)
1/16	0.070	1.80	0.016	0.408
3/32	0.103	2.65	0.031	0.791
1/8	0.139	3.55	0.031	0.791
3/16	0.210	5.30	0.062	1.581
1/4	0.275	7.00	0.094	2.397

12. There is no sanitary reason for a minimum radius on external angles which are in product contact. Nevertheless, it is customary to relieve sharp edges slightly for safety reasons. Care must be taken so that any such relieved edges do not create cracks or crevices upon assembly of component parts such as flanged joints. (See item E 5.b above.)
13. Gaskets shall be either removable or bonded.
14. Grooves in gaskets shall be no deeper than their width, except as appropriate for gasket sealing applications on large equipment, unless the gasket is readily accessible, readily removable, and reversible for cleaning.
15. Gasket grooves or gasket retaining grooves in product contact surfaces for removable gaskets shall not exceed 1/4 inch (6mm) in depth or be less than 1/4 inch (6mm) wide except those for standard O-rings smaller than 1/4 inch (6mm) cross section and those specified by specific 3-A Sanitary Standards.

Dimensions of gasket grooves or gasket retaining grooves for bonded gaskets are at the discretion of the fabricator.

16. Bonded rubber and rubber-like materials and bonded plastic materials having product contact surfaces shall be bonded in a manner that the bond is continuous and mechanically sound so that when exposed to the conditions encountered in the environment of intended use and in cleaning and bactericidal treatment or sterilization the rubber and rubber-like material or plastic material does not separate from the base material to which it is bonded.
17. Holes in product contact surfaces for removable retaining pins shall be at least 5/32 inch (4mm) diameter.
18. All product contact surfaces shall be self-draining except for normal adherence. When necessary for essential functional or safety reasons, the equipment alternatively may be drainable.

Equipment bottoms shall be constructed so they will not sag, buckle, or prevent complete drainage.

19. When mechanical cleaning is intended as the only means for cleaning, the equipment design shall assure that all product contact surfaces will be free of cracks, crevices, and dead end areas that could impede cleaning. Also, the prescribed mechanical cleaning procedure shall be proven to effectively clean the equipment.

If mechanical cleaning is intended to clean only portions of the equipment, the operator's manual shall clearly identify those components which require disassembly and manual cleaning.

All equipment utilizing mechanical cleaning shall be designed to be readily accessible for periodic inspection of all product contact surfaces to assess cleaning and inspection of gaskets.

20. All manually cleaned product contact surfaces shall be easily accessible for inspection and cleaning, either when in an assembled position or when removed. Removable parts shall be readily demountable.
21. All openings into the interior of equipment shall be protected against the entrance of contaminants.
22. When mechanical agitators are provided, refer to the 3-A Sanitary Standards for Shear Mixers, Mixers, and Agitators, Number 73-.
23. Rotating shafts, other than those covered by 3-A Sanitary Standards for Shear Mixers, Mixers, and Agitators, Number 73-, shall not have lubricated bearings, including sealed bearings, in the product contact area except as described below. Such lubricated bearings shall be mounted to provide a minimum of 1 inch (25mm) exterior open space on the shaft between the mechanical seal for the bearing and the nearest part of the sanitary seal or the opening to the product contact area. The 1 inch (25mm) minimum space shall be open to the atmosphere and be easily accessible for inspection and cleaning.

Where for specialized functional or safety reasons bearing assemblies must be positioned within or in close proximity to the product contact areas, alternative designs will be considered. The alternative design shall provide for:

- a. Means to completely isolate the bearing assemblies and provide for the collection of all lubricants in the event of a catastrophic bearing or seal failure, or
- b. Lubricant impregnated bearing materials which have been reviewed and accepted by the Dairy Grading Branch.

Alternative designs shall be considered on a case by case basis. The use of food grade lubricant is not considered as an alternative to the above criteria for lubricated bearings.

- 24. Seal assemblies for rotary shafts for liquid applications shall be of the packless type, of sanitary design, durable for the application, and readily demountable. Stacked or nested "V" ring seals are **NOT** considered as packing and may be used.
- 25. Seal assemblies for rotary shafts for dry products applications shall be of sanitary design, durable for the application, and readily removable. Shaft seal designs using adjustable followers are acceptable if provisions are made for easy removal. Air purge type seal designs may also be acceptable.

Woven or braided packing material may be used only for dry product applications when the material is discarded when the unit is disassembled for cleaning. Reuse of woven or braided packing material is prohibited.

- 26. Personnel entry openings into equipment shall be not less than 15 inches (381mm) by 20 inches (508mm)(oval) or 18 inches (457mm)(round) in diameter.
- 27. The personnel entry opening cover shall be of the inside or outside swing type. If the cover swings inside it shall also swing outside away from the opening for disassembly and cleaning. No threaded or ball joints shall be employed within the product zone to attach the cover and its appendages. The cover and its appendages shall be removable without tools. The cover for a top-entering opening shall be of the outside swing type only.
- 28. Covers for inspection openings into equipment are not limited to round or oval shapes. Regardless of shape, the opening cover must protect the product, be easily cleanable, and meet the criteria of item E 29.

29. Requirements for covers of openings into tanks or other vessels:
- a. Sufficiently rigid to prevent buckling.
 - b. Self draining including "U" channel bracing or frames
 - c. Adequate, conveniently located, with welded or formed handles.
 - d. If not gasketed, a downward flange of at least 3/8 (9.5mm) inch along all exterior edges is required.
 - e. Close fitting.
 - f. If hinged, the hinges shall be sanitary type and readily removable for cleaning and inspection. (Continuous piano type hinges are not acceptable.)
 - g. Any opening(s) in the cover shall have an upward flange of at least 3/8 inch (9.5mm).
 - h. If braces or frames are made of hollow components, the integrity of the component shall not be compromised by drilling into the hollow interior. If bolting is required, welded studs to the exterior or fully welded sleeves shall be employed.
 - i. Gasket material shall be solid. Open cell foam, smooth surfaced closed cell foam or hollow interior materials are not acceptable. (This does not exclude the use of hollow, inflatable bladders for bag clamps on bag filling equipment or isolation devices.)
 - j. Covers shall be designed so when opened liquid from the exterior surfaces will not drain into the vessel and when fully opened drops of condensate on the underside will not drain into the vessel.
 - k. Bridges and fixed covers shall slope to the outside edges of the tank for complete drainage and shall have a raised flange not less than 3/8 inch (9.5mm) in height where the edges meets the main covers. Bridges and fixed covers shall be integral or welded to the lining and shall be installed so the underside is accessible for cleaning and inspection without completely entering the vessel. Bridges shall not exceed 24 inches (610mm) in width if they are intended for manual cleaning.

30. Dry products equipment shall be equipped with dust-tight covers or means for dust removal and control. A bag type dust removal system that purges the collected dust back into the dump hopper or human food system shall not be used.
31. Continuous, piano type hinges may be used on electrical boxes used on dairy processing equipment when they are located well outside of the product zone and not subject to product residues or repeated washing. (See Item E 43.j)
32. Mechanical cleaning spray devices not of sanitary design shall be removed after cleaning and shall be readily accessible and readily removable.
33. The rail (breast) of the lining of a tank shall be integral with the lining of the tank and be sloped away from the lining.
34. Air vents for product vessels shall be of sanitary design and designed to protect against entrance of foreign material. For bulkheaded vessels or tanks, the air vent openings shall be located within a processing room or area.
35. Any guards required by a safety standard that prevent accessibility for cleaning and inspection shall be designed to be self draining and readily removable.
36. Product piping and other tubular components shall be installed with good workmanship and supported in such a manner that will prevent sagging. Product piping shall be installed with sufficient slope for drainage.
37. Any part of the shaft of a pneumatic or hydraulic cylinder that enters the cylinder and extends over exposed product or a product contact surface shall be provided with a sanitary shield or be of a sanitary design. Sanitary shielding can be accomplished with a long drip plate (so that all exposed product and product contact surfaces are shielded when the shaft is fully extended), or any other shield arrangement that protects the surfaces and product. A sanitary design may include; double seals (with 1-inch of clear space between them, provided the space between the seals is not in the product zone), doubling the length of the shaft so the part that enters the cylinder never extends over the product zone, or other sanitary design features.

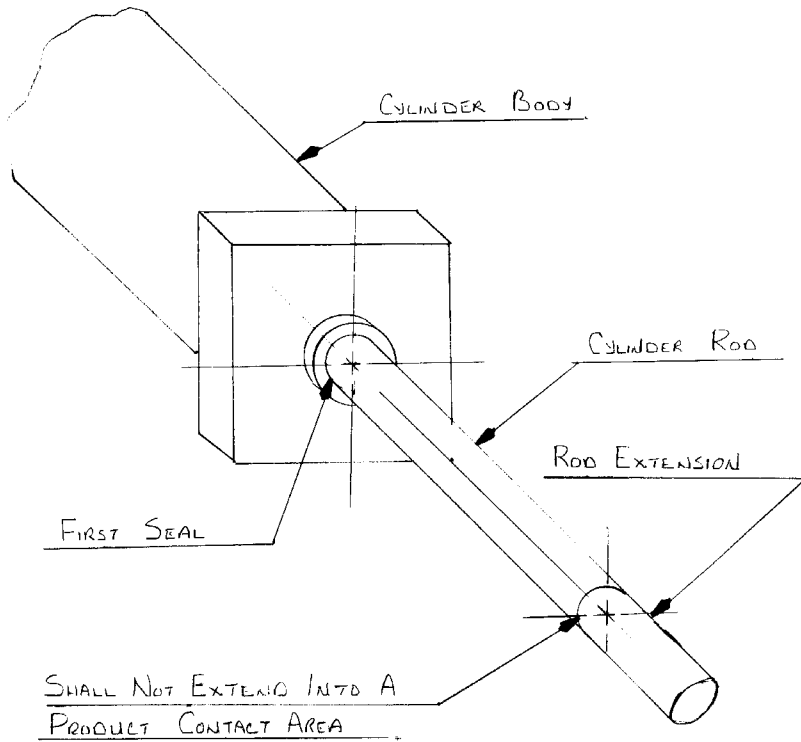
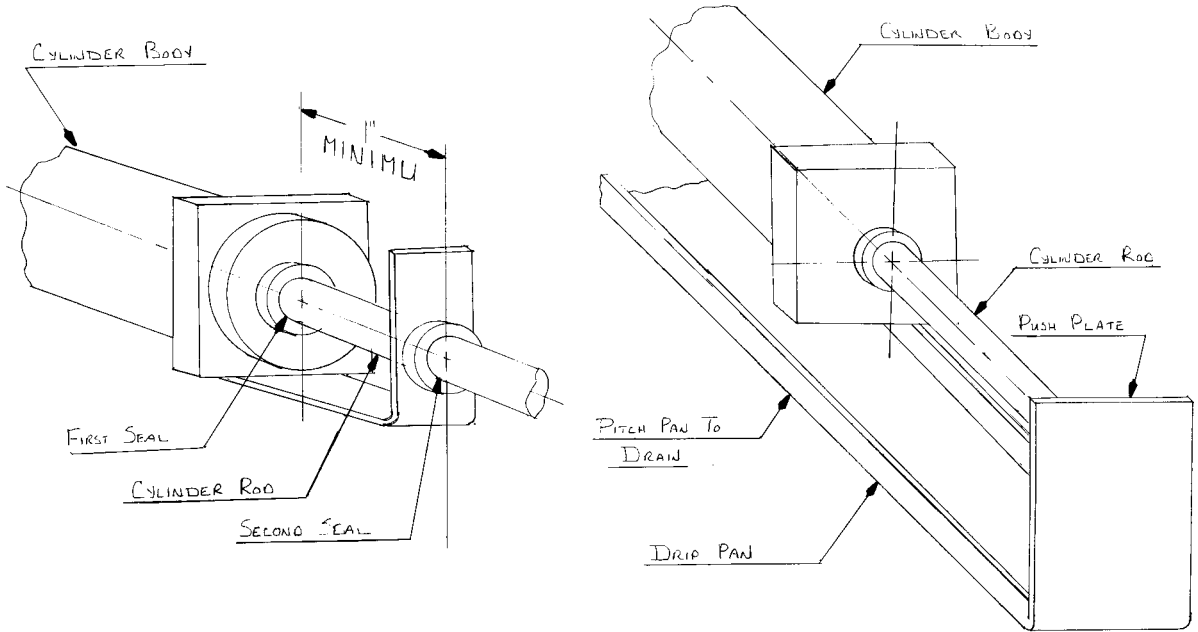

38. When a high pressure hydraulic hose is located on a machine so that its rupture could allow product contamination, that portion of the hose shall be enclosed in a larger secondary protective hose or tube, or other means to protect the product from contamination shall be provided. Hydraulic fittings shall not be located directly over product contact surfaces.
39. Flexible connectors for dry products having product contact surfaces shall have straight sides without corrugations or sewn seams and shall be readily cleanable, except that; flexible connectors which are 18 inches or less long and are used in a vertical position may have corrugations which have a radius of not less than 0.5 in. (12.7 mm) and which are no deeper than their width.
40. Pop rivets, rivets, recessed socket-head and slot-head style bolts or screws are not acceptable on product contact surfaces. If a fastener is necessary in a product contact area, a bolt of hex-head design and properly sealed shall be used. Use of bolts should be the last alternative.
41. Welded, threaded studs are preferred fabrication over threaded blind holes.
42. Exposed product, product contact surfaces, or product contact surfaces of packaging materials shall be protected from contamination from mechanical and nonproduct contact areas of the equipment. This may be accomplished by the use of catch pans or shields of sanitary design which drain away from the product contact area.
43. Nonproduct contact surfaces including frame assemblies, drive assemblies, mechanical actuators, support members, etc., shall be designed and fabricated so as not to contribute to unsanitary conditions. These areas are to be such that they do not detract from a clean environment for food processing. Primary concern shall be focused on those nonproduct contact surfaces which are in close proximity to product contact surfaces and may be subjected to product residues and splashing. Nonproduct contact surfaces which are located well outside of the product zone and not subjected to product residues and splashing **do not** have direct sanitary significance and **should not** be criticized for construction characteristics. In general, the further away from the product zone the less the nonproduct contact surfaces are to be criticized.

The following criteria shall apply **only** to those nonproduct contact surfaces which are subject to product residues and splashing.

- a. Nonproduct contact surfaces, including frame assemblies, shall be free of pockets and crevices and be readily cleanable. This can be attained by continuous welding, however, skip welding may be employed provided that

intervening crevices are suitably sealed or caulked. Although epoxy metal or silastic type caulking materials may be used for such sealing, it should be realized that this is usually only a temporary measure and that periodic maintenance will be required. Epoxy metal or silastic type caulking materials are significantly more durable when the materials can be applied to mating components prior to assembly.

2. If braces or frames are made of hollow components, the integrity of the component shall not be compromised by drilling into the hollow interior. If bolting is required, welded studs to the exterior or fully welded sleeves shall be employed.
- c. Recessed socket-head screws, slot head screws, and exposed threads are not acceptable on nonproduct contact surfaces where solid or liquid product residues may drip, drain, be drawn, splash, or accumulate. (**Note for Inspectors:** areas subjected to only water should not be criticized.)
- d. Where applicable, motor housings and hydraulic cylinders shall be isolated from product contact areas by sanitary shields or guards. (**Note for Inspectors:** when properly shielded or located where they are not subject to product residues and splashing, construction details of these components should not be criticized.) See Item E 37.
- e. Surfaces to be coated shall be effectively prepared for coating. This preparation may include, but is not limited to, grinding of welds, polishing of cast surfaces, cleaning of surfaces so the covering adheres properly, etc.

Stainless steel equipment frames and exterior nonproduct surfaces may be glass beaded if desired. If not made of corrosion-resistant metal, they shall be painted or coated.

- f. Legs or casters shall provide a clearance between the lowest fixed point on the equipment and the floor of at least 4 inches (102mm) when the equipment base outlines an area in which no point is more than 12 ½ inches (318mm) from the nearest edge of the base, or a clearance of at least 6 inches (152mm) when any point is more than 12 ½ inches (318mm) from the nearest edge.
- g. Casters, if provided, shall be easily cleanable, durable, and of a size that will permit easy movement of the equipment. If bolted, excess threads should be cut off and covered with a "dome" type nut.

- h. Adjustable legs shall have casters, ball feet or have flat, load bearing feet suitable for sealing to a floor with no exposed threads. If the equipment is heavy and requires leg pads to distribute the load or must be bolted to the floor, such pads or bases shall be sealed or grouted to the floor.
- i. Equipment with a closed base to be mounted on the floor shall have the base sealed in a bed of mastic or grouting.

When the equipment is designed to be installed on a slab or island, the dimensions of the slab or island shall be such that the base of the equipment will extend beyond the slab or island at least 1 inch (25mm) in all horizontal directions. The slab or island shall be of sufficient height so that the bottoms of all product connections are at least 4 inches (102mm) above the floor. The interface surface of the slab or island shall be coated with a thick layer of waterproof material, which will harden without cracking. The junction of the equipment base and the slab or island shall be sealed.

- j. Control panels and electrical boxes shall be continuously welded, or mounted with approximate 1 inch (25mm) stand-offs, or properly sealed with caulking material to the frame or wall.

This does not preclude use of piano type hinges on electrical boxes used on dairy processing equipment when they are located well outside of the product zone and not subject to product residues and splashing. (See item E 31 for additional guidance on hinge usage.)

- k. Company name or information plates shall be fully bonded to the unit. Welding of metal plates or adhesive Mylar-type stickers are preferred. However, plates may be bonded with a suitable adhesive or the crevice conditions can be sealed with caulking. The use of pop rivets is not acceptable. (**Note for Inspectors:** name plates on motors, gear drives, bearing bosses, actuating cylinders,, etc., which are located well outside of the product zone and not subjected to product residues and splashing **do not** have direct sanitary significance and **should not** be criticized for construction characteristics.)

THE FOLLOWING SPECIAL CONSIDERATION SECTIONS PROVIDE CRITERIA AND GUIDANCE IN ADDITION TO THOSE PROVIDED IN THE PREVIOUS SECTIONS. UNLESS SPECIFICALLY MODIFIED BY THESE SPECIAL CONSIDERATION SECTIONS, ALL MATERIALS AND FABRICATION CRITERIA IN SECTIONS D AND E APPLY.

June 2001

F. SPECIAL CONSIDERATIONS FOR PASTEURIZATION EQUIPMENT:

1. When the equipment or installation of a processing system includes a High Temperature Short-Time (HTST) or Higher Heat Shorter-Time (HHST) pasteurizer, USDA recommends that details of the proposed pasteurizer system be additionally presented for review and acceptance by the State regulatory authority responsible for inspecting, timing, and sealing the system upon installation. The State regulatory authority personnel receive training and guidance from the U.S. Public Health Service (USPHS), a Federal agency of the Food and Drug Administration (FDA) of the Department of Health and Human Services. Dairy Grading Branch of USDA defers to USPHS for engineering expertise and leadership in the public health aspects of pasteurizer design and operation.

The "3-A Accepted Practice for the Sanitary Construction, Installation, Testing and Operation of High Temperature Short-Time and Higher Heat Shorter-Time (HHST) Pasteurizers, Number 603-" should be used as guidance for design and installation of HTST systems. Any new or unusual aspects of such systems should be presented for review to the state inspection agency or to the Milk Safety Branch, (HFF-346), FDA, Department of Health and Human Services, 330 C Street, S.W., Washington, DC 20204. Telephone 202-205-8178, FAX 202-205-5560.

G. SPECIAL CONSIDERATIONS FOR EXPOSED PRODUCT CONVEYORS:

Exposed product conveyors will be evaluated using the criteria of the 3-A Sanitary Standards for Mechanical Conveyors for Dry Milk and Dry Milk Products, Number 41-; or, the 3-A Sanitary Standards for Belt-Type Feeders, Number 75-, as appropriate. Exposed product conveyors which do not meet the scope criteria of the above referenced standards shall meet the following criteria.

1. Nonsanitary construction for drive mechanism components, such as, riveted roller type chains, cleated belts, round resilient belts, and friction drives, may be considered as nonproduct contact surfaces provided one of the following methods of isolation is used.
 - a. A minimum of 6 inches (152mm) space between the product contact area and the demarcation of the nonproduct contact area containing the drive components is required when the product contact area boundaries are designated by open construction such as guide rails, sanitary shields or dividers less than 4 inches (102mm) high, or other clearly identifiable boundary demarcations. A clearly identified demarcation may include belt width, or equipment intended to locate product in a set position on the conveyor belt such as a funnel or feed conveyor.
 - b. A minimum of 1 inch (25mm) space between the product contact area and the demarcation of the nonproduct contact area containing the drive components is required when the product contact area boundaries are designated by closed construction such as close fitting shields enclosing the entire drive component section or by a solid sanitary shield of 4 inches (102mm) or greater in height provided the shields extend over the conveyor material a minimum of 1 inch (25mm) from the conveyor material edge and the gap between the conveyor material and the shield is not greater than 1/8 inch (3mm).
2. Conveyor belts having direct product contact shall be endless. Metal stitching, metal clips, or metal lacing are not acceptable methods of joining belt ends.

Belts which have absorbent core or backing material, or which have core or backing materials that allow liquid to wick into the core or backing material (see Item G 11) shall have the these surfaces sealed with:

- a. The same material as used for the product contact surface; or
- b. A sealant which complies with the applicable Food and Drug Administration regulations for repeated food contact for the product which is being conveyed.

All sealants applied shall be equally as durable as the belting material and applied in sufficient thickness so that it shall remain intact without peeling, blistering, delaminating, flaking, etc., during the expected life of the belt.

If it can be proven that liquids will not wick along core or backing material fibers, sealing the edges of the belt is not required. (see Item G 11.)

3. When continuous, solid sheet belting material is used for direct product contact, the area between the top and bottom runs of the belting material and at the side frame areas may have nonsanitary construction provided liquids, debris, or product residues are prevented from migrating onto the product contact surfaces.

This area between the solid sheet belts may have exposed bolt heads (if needed for engineering reasons) and the welds need only to be continuous, pit and snag free, with no minimum radii or polishing required.

4. When open belting material is used for direct product contact, the area between the top and bottom runs of the open belting material and at the side frame areas may have nonsanitary construction only when liquids, debris, or product residues are prevented from migrating onto the product contact surfaces by the use of sanitary constructed shields and guides.

5. Open belting and approved plastic link belting shall be provided with an integral, mechanical cleaning device that is located so all exposed surfaces of the belting, rollers, and sprockets are automatically cleaned, except that, if the belt is of a size manageable by one person and weighs 51 pounds or less, is readily accessible and readily removable, it may be cleaned in a COP tank..

Cleaning solution catch pans or trays shall be designed to be self draining and accessible for cleaning and inspection. If these pans or trays are left in place during operation and collect product or whey for human consumption, they shall meet all product contact surface requirements.

Substitution of manual cleaning techniques using hand held, high pressure spray systems is not satisfactory.

6. Conveyor rollers for either direct product contact or for the support of belting material shall comply with the applicable following criteria:
 - a. They shall be of sanitary design and constructed from acceptable materials.
 - b. Half knurled or slight roughened surfaces are acceptable provided there is a mechanism for releasing the tension on the belting and the rollers are fully accessible for inspection and cleaning.
 - c. End cap junctures on hollow rollers shall comply with the permanent joint criteria of Section E 5.
 - d. Rollers shall not contain integral lubricated bearings, including sealed, ball or roller style bearings. See Item G 7 for guidance on internally driven rollers.
 - e. Recessed bushing or bearing surfaces shall be of sanitary design appropriate for mechanical cleaning or be readily removed for daily manual cleaning.
 - f. The diameter of a recessed bearing cavity shall be greater than its depth.
7. Internally driven rollers shall be of sanitary design. The designs shall assure that the internal lubricants can not leak and contaminate product and the product contact side seals are of sanitary design. Each design proposal shall be evaluated on a case by case basis.
8. Flat top, link style or molded modular belting for direct product contact shall be evaluated for acceptance on a case by case basis.
9. Conveyors which run partially submerged in chilled brine systems are not required to meet the sanitary construction requirements. Bent wire conveyors and plastic link conveyors which are not acceptable for other exposed product conveyors may be acceptable for brine system discharge conveyors on a case by case basis. The conveyors shall be designed so that lubricated bearings, including sealed bearings, are not immersed in the brine and so the conveyor can be removed from the brine for cleaning as needed. Such conveyors shall not be cleaned while immersed in the brine tank or flume unless the tank or flume has been drained.

10. When conveyors discharge into product hoppers or vessels or if the conveyor is stacked above another product conveyor, all bearings, drives and other nonsanitary areas shall be shielded to prevent contamination of the product in the hopper or vessel below.
11. Belting which includes fiber core or backing material shall be subject to a wicking test. Commercially available, water-based food coloring shall be the test solution. Undiluted food coloring shall be applied directly to the backing material or imbedded fibers at a cut edge of the belting. Any coloring penetration or migration along the fibers greater than 1mm shall be considered evidence of unacceptable wicking properties of the materials.
12. Side guides or flights, if incorporated into the belting, shall be fully heat welded or bonded to the belting surface with no cracks, crevices, pits or folds. There shall be no radii requirements for these junctures.

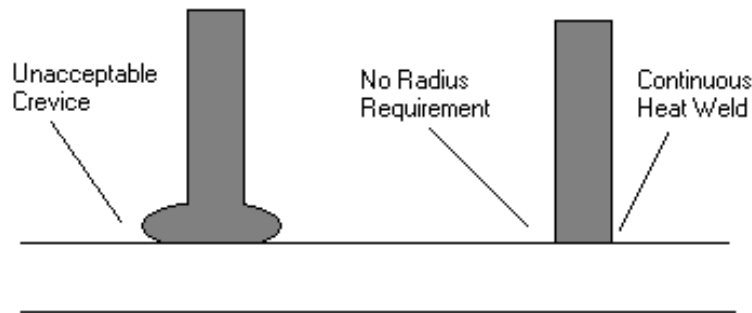

H. SPECIAL CONSIDERATIONS FOR CHEESE BRINE SYSTEMS AND RELATED EQUIPMENT:

1. Stainless steel tanks should be made from 316 series stainless steel. A 2B mill finish is satisfactory. All welds shall be continuous, snag and pit free. There are no minimum radii requirement for internal angles.
2. Concrete or ceramic tile covered tanks shall have a smooth, cleanable interior surface. Exposed aggregate, pockets, bubbles, form impressions, missing grouting, flaking or spalling of the surface is unacceptable. If a coating or sealer is used, it shall comply with applicable FDA requirements for indirect and repeated food contact.

Pit tanks shall have perimeter curbing which extends at least 1 foot (305mm) above the floor level of the room.

3. The design and construction of the wooden frames or other components for fiberglass tanks shall be substantial enough to bear the weight loading when the tank or flume system is filled with brine without stressing or breaking the fiberglass coating.
4. Fiberglass covered components shall be constructed with a final, resin rich coating that results in a smooth cleanable surface free of pits, checks, cracks, ripples or waves on both interior and exterior surfaces.
5. All openings, bored holes for pipe or conduit passage, cut-outs, or attachments to the fiberglass covered surfaces of the tank shall be fully sealed or fiberglass covered to prevent the entrance of moisture into the wooden frame. Similar openings in concrete tanks shall also be sealed to prevent exposure to rough aggregate surfaces.
6. When fiberglass tanks are stacked or "piggy-backed" the exterior of all but the lowest tank shall meet the same fabrication criteria as the interior surfaces of the tank which contact the brine and product.
7. Stacked or "piggy-backed" tanks or flumes shall provide the following clearances:
 - a. Between each tank and any tank above it shall be at least 18 inches (457mm), as measured between any projections or cross beams of the upper tank and the top lip of the lower tank except that,
 - i. if the upper tank has ribs or cross beams which project downward 12 or more inches (305mm), the clearance shall be 24 inches (610mm).

- ii. if the bottom tank is divided into narrow flumes (less than 20 inches (508mm) wide) which interfere with movement in the bottom tank for manual cleaning, the clearance shall be 24 inches (610mm).
- b. Between the uppermost tank top lip and the ceiling of the room shall be at least 18 inches (457mm). If there are ceiling joists or beams projecting downward there shall be compensating clearance to facilitate manual cleaning.

Note: Lesser clearances may be considered if the brine tank or flume system is provided with a mechanical spray cleaning system.

8. The clearances between the bottom of a tank and floor shall be:

Tank Width (in feet)	Minimum Clearance (in inches)
Up to 3 (0.9m)	12 (305mm)
3 to 6 (0.9 - 1.8m)	20 (508mm)
6 to 8 (1.8 - 2.4m)	22 (559mm)
8 to 10 (2.4 - 3.0m)	24 (610mm)
10 to 12 (3.0 - 3.7m)	26 (660mm)
12 to 14 (3.7 - 4.3m)	28 (711mm)
14 to 16 (4.3 - 4.9m)	30 (762mm)
Over 16 (4.9m)	36 (914mm)

Note: All tank measurements are exclusive of projecting ribs, cross beams, or top lips.

- 9. Perimeter clearance between a tank or flume system and the walls of the room shall be at least 24 inches (610mm).
- 10. The aisle spacing between adjacent tanks shall be at least 24 inches (610mm), except that two long rectangular shaped tanks may be butted against each other on the long side in accordance with the following criteria:
 - a. There is at least 24 inch (610mm) aisle clearance on the remaining four sides.
 - b. The upper crevice between the two tanks is appropriately sealed.
 - c. The underside contact points are properly sealed and form a flush surface with the bottom of the tanks. Deep recesses created by tank lips are unacceptable.

11. When fiberglass tanks or flumes are mounted directly on the floor, the following criteria apply:
 - a. The tanks shall be firmly and completely bonded to the flooring materials so that water or other liquids can not seep under the tank or flume.
 - b. The tank to floor juncture shall have a curved cove molding with at least a 1 inch (25mm) radius to facilitate cleaning of the juncture.
12. When tanks or flumes are stacked or "piggy-backed", the tanks shall be readily accessible and the access shall be designed to prevent contaminants from entering the tanks.
13. Provision shall be made so the brine can be pumped out of the system so the tanks or flumes can be cleaned. Separate brine storage tanks or product storage tanks may be used.
14. Plastic or rigid PVC piping and associated adhesives suitable for potable water systems may be used for the transport of brine. Brine piping shall be rigidly supported and self draining.
15. Butterfly type valves are acceptable for use on brine distribution piping.
16. Threaded fittings may be used for brine spray nozzles.
17. Pumps complying with the criteria of the 3-A Sanitary Standards for Centrifugal and Positive Rotary Pumps for Pumping Cleaning and Sanitizing Solutions, Number 47-, for circulating brine may be used.
18. Specially constructed Archimedes screw or jet type pumps may also be used to circulate brine provided that the construction materials are corrosion resistant and there are no lubricated bearings above or under the brine surface. All motors, drive assemblies, lubricated bearings, etc., shall be appropriately isolated or shielded to prevent contamination of the brine.
19. Baffles, gates, baskets, frames, racks, and other appurtenances shall be mechanically sound, sufficiently strong for the intended use, and corrosion resistant. Parts shall not be painted. Threaded and bolted construction, woven plastic or stainless steel screen material, and braided stainless steel cables that are not immersed in the brine are satisfactory. There are no minimum radii requirements for these components.

20. Baskets, frames, or racks which are removed from the brine for cleaning and storage or staging for loading shall not be stored on the floor. Sanitary storage racks or platforms shall be provided.
21. Systems shall have facilities, suitable to their size, for skimming, filtering, cooling, and strength adjustment of the brine. Pasteurization or ultraviolet (UV) treatment of the brine is encouraged.
22. A hoist(s), if used, shall have all nonsanitary surfaces such as the drive, hoist chain, cables, pulleys, rollers, etc., shall be provided with a sanitary shield(s) to protect any exposed product, product contact surfaces, or brine below the hoist.

I. SPECIAL CONSIDERATIONS FOR CHEESE MOLDS:

General

1. All mold surfaces are to be considered product contact surfaces as most users routinely save cheese whey solids and butterfat for human consumption.
2. The radius requirements of Fabrication Items E 11 and E 12 shall apply except when required for:
 - a. Maintaining the desired shape of the cheese.
 - b. Functional requirements during the molding, cooling, or friction welding of plastic components.
 - c. Bending of thin, smooth or perforated metal sheets of 16 gauge thickness or thinner. In such instances, internal radii shall be not less than 1/32 inch (0.8 mm) and the short side of a 180 degree bend shall not exceed 3/8 inches (9.5mm) in length. See Figure I.1 for an example of an acceptable formed stiffening rim on the top of a metal cheese mold.

Figure I.1 Example of a formed stiffening rim on the top of a metal cheese mold.

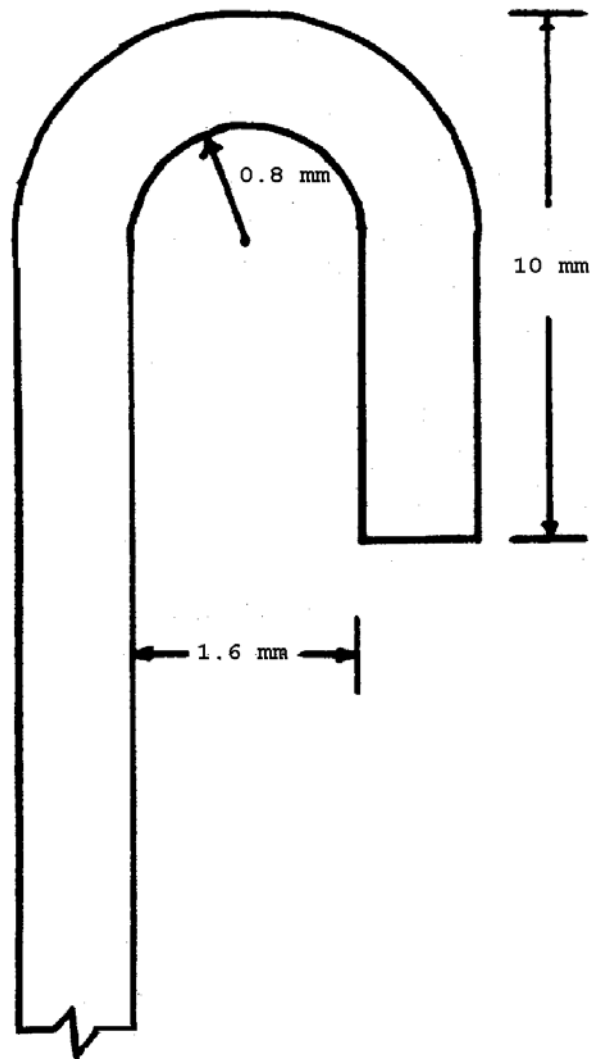

3. Mechanical cleaning is required when component perforations are 1/32 inch (0.8 mm) or less in diameter, or when component parts such as a bonded plastic cheese cloth are cleaned as assembled units.
4. All component parts are to be fully accessible for inspection or cleaning. Demountable parts are to be readily demountable. There shall be no noninspectable surfaces.

5. When close tolerance areas are required for functional reasons, perforations shall be located to facilitate cleaning. See Figures I.2 and I.3 for examples of alternate placement of required perforations.

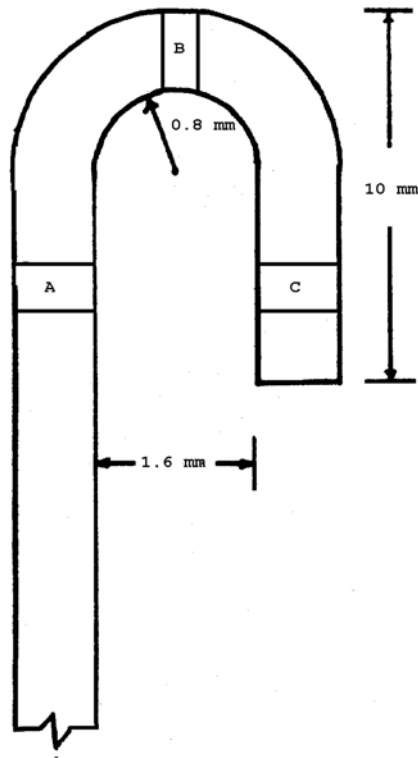
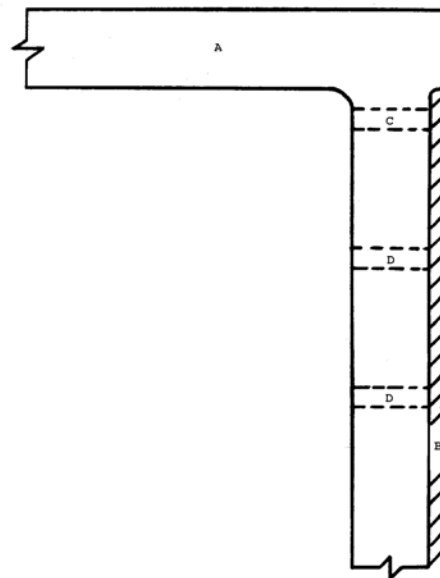

Figure I.2 Perforations in a formed stiffening rim on the top of a metal cheese mold is required at one or more of locations A, B, or C to facilitate cleaning.

Figure I.3, key:

- A. Cheese mold body
- B. Perforated drain screen on inside
- C. Required perforation for cleaning
- D. Perforations for whey drainage



6. When friction welding is used to attach plastic components, all deformed material shall be removed to eliminate any cracks, crevices, pits or folds. No radius is required at these junctures.

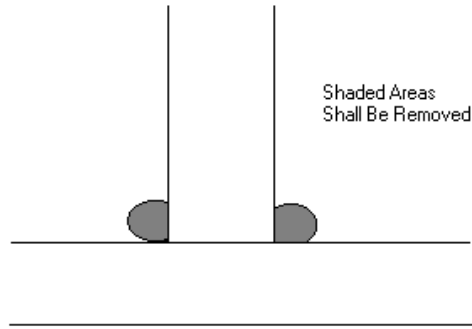

Stainless Steel Molds

7. Nonperforated metal components shall be continuously welded, ground and polished as required by Items E 1 and E 5a.
8. Spot welding of perforated screen material may be utilized in accordance with the following criteria (See Figure I.4):
- The weld shall be at the apex of a preformed dimple in the screen.
 - The entire apex surface of the dimple shall be welded.
 - Spot welded perforated screens shall be separated by at least 1/16 inch (1.5mm).
 - The preformed dimple in the screen shall be no deeper than its width.

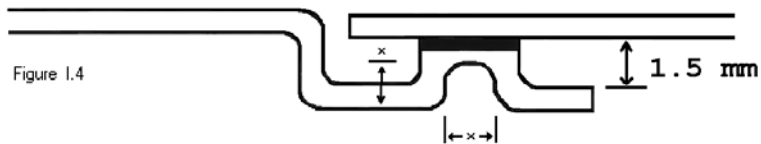

9. Glass beading of product contact surfaces is acceptable under the guidance of Item E 1.

10. Component parts may be attached with spring tension, positioning pins, "R" clips, etc. during routine use and cleaning procedures. See Items 1 3 and I 4.

Plastic Molds

11. All plastic molds shall require mechanical cleaning.
12. Mold strengthening ribs, especially those located on mold lids, shall not create nondrainable pockets or other obstructions to free draining.
13. Heat or solvent welds or bonds of plastic materials shall be joined in a manner that the joint is continuous and mechanically sound so that when exposed to the conditions encountered in the environment of intended use and in cleaning and bactericidal treatment the joint does not separate. (See item I 6.)
14. All injection sites, perforations, machined surfaces, etc. shall be free of ripples, distortion, flashing, loose strings or shavings of plastic.
15. Plastic parts shall not be fastened together with threaded fasteners.

Mold Washing Machines (Non-recirculating systems)

16. All washing machines shall be equipped so the cleaning solution temperature is automatically controlled by the use of a temperature control system with a response range of +/- 5 degrees F (+/- 3 degrees C). The temperature control sensor shall be located in the cleaning solution return line.

Automatic solution concentration and addition controls are encouraged.

17. Washing machine cabinets and interior support structures shall be constructed of stainless steel.
18. Washing machines are exempt from the requirements of fabrication Items E 1, E 8, E 11, E 14, E 15, and E 16.
19. Internal welds shall be continuous, smooth, pit, and snag free. Grinding and polishing of welds is not required.
20. Bolted construction creating cracks and crevices shall be avoided, except that, threaded fittings for spray nozzles and Tri-Clamp type fittings may be used.
21. Chin type conveyors with ball and joint construction shall not be used.

June 2001

I - 5

J. SPECIAL CONSIDERATIONS FOR MECHANICAL CLEANING SYSTEMS FOR LARGE EQUIPMENT OR VESSELS:

Note: These guidelines are not intended for the construction of small parts washers, COP tanks or cheese mold washers.

1. All appropriate sections of these guidelines apply to large vessels or equipment designed and fabricated for mechanical cleaning. Special attention shall be placed on Section E, items E 18, E 19, E 20, E 27, E 28, and E 29.
2. Equipment and appurtenances included in a mechanical cleaning system for large vessels or equipment for which there are applicable 3-A Sanitary Standards shall comply with all criteria within those standards except as specifically exempted by this Section.
3. The mechanical cleaning system shall include a mechanical cleaning unit dedicated to and used exclusively for the supply and recirculating of cleaning or sanitizing solutions. The mechanical cleaning unit may be provided as an appurtenance to the equipment or may be an existing unit provided by the processing facility. The mechanical cleaning unit may include but is not limited to the following:
 - a. Cleaning and sanitizing solution pump(s);
 - b. Cleaning and sanitizing solution tank(s);
 - c. Cleaning and sanitizing solution supply and return valve(s) and valve manifold(s);
 - d. Fittings;
 - e. Cleaning and sanitizing solution heat exchanger(s) or steam injector(s);
 - f. Instrument fitting(s) and;
 - g. Strainers.
4. All cleaning and sanitizing solution contact surfaces included in recirculating cleaning circuits shall comply with the materials, design and finish requirements of product contact surfaces, except for those of castings for cleaning and sanitizing solution heat exchanger(s)/steam injector(s), and for pumps meeting 3-A Sanitary standards for Centrifugal and Positive Rotary Pumps for Pumping Cleaning and Sanitizing Solutions, Number 47-.
5. A No. 2B finish is acceptable for all cleaning and sanitizing solution contact surfaces.

6. Castings for cleaning and sanitizing solution contact surfaces shall be at least as smooth as scales for investment casting on the GAR C-9 (200 μ in) Cast Microfinish Comparator, and relatively free of pits, folds, and crevices in the final fabricated form.

Copies of the *GAR C-9 Cast Microfinish Comparator* can be obtained from GAR Electroforming Division, Box 340, Danbury, CT 06813-0340, (203) 744-4300.

7. There shall be no threads on cleaning and sanitizing solution contact surfaces.
8. Cleaning and sanitizing solution pumps designated solely for mechanical cleaning recirculating shall comply with the 3-A Sanitary standards for centrifugal and Positive Rotary Pumps for Pumping Cleaning and Sanitizing Solutions, Number 47-.
9. All valves to be mechanically cleaned shall be provided with automatic actuators which shall be programmed to pulse during the cleaning cycle so that all product contact surfaces of the sealing face and the gaskets are adequately cleaned.
10. All manually operated valves shall be disassembled and hand cleaned during each cleaning cycle.
11. Each separate cleaning circuit, including product and cleaning and sanitizing solution lines, shall be provided with sufficient access points, such as valves, fittings, or removable sections to make possible adequate inspection and examination of representative interior surfaces.
12. The mechanical cleaning unit shall be designed so the suction intake of the primary circulating pump shall be flooded at all times during the cleaning cycle.
13. Cleaning solution temperature shall be automatically controlled by the use of a temperature control system with a response range of +/- 5 degrees F (+/- 3 degrees C). The temperature control sensor shall be located in the cleaning solution return line.
14. There shall be no cross-connections between any cleaning and sanitizing solution circuit and any product circuit. Provisions shall be made to effectively separate and positively prevent the commingling of product and cleaning and sanitizing solutions during processing. This may be accomplished by the use of physical disconnections, block and bleed valving, or leak proof valves.

15. Connection of the mechanical cleaning unit and the safe water supply shall meet all installation codes of the appropriate regulatory agency.
16. Reverse osmosis permeate or cow water (condensed vapors removed from liquid dairy products by vacuum evaporation) produced in compliance with USDA, Dairy Grading Branch criteria may be used as a pre-rinse directed to drain or to make up cleaning solutions, but cannot be used as a final rinse or to make up sanitizing solutions unless specifically approved by the appropriate State water control regulatory authority and USDA as process water. Approvals of this nature shall be handled on a case by case basis.

K. SPECIAL CONSIDERATIONS FOR LACTOSE EQUIPMENT:

1. Product contact surfaces upstream from the point where the dairy fats and solids are removed from the mother liquor shall meet the requirements for sanitary design, materials and fabrication of dairy processing equipment as outlined in sections D and E. For example, the point of dairy fat and solids separation in a lactose basket centrifuge occurs as the mother liquor passes through the basket screen.
2. Product contact surfaces from which liquids may drip, drain, diffuse, or be drawn into contact with the separated dairy fat and solids shall also meet the requirements for sanitary design and construction of dairy processing equipment as stated in item 1 above. This may include some surfaces downstream from the point where the dairy fats and solids are removed from the mother liquor.
3. All other surfaces in contact with the lactose crystals **and** from which liquids will not drip, drain, diffuse, or be drawn into the dairy by-products may be constructed using the following criteria:
 - a. Equipment shall be constructed of non-toxic material meeting applicable Food and Drug Administration regulations. The materials shall be resistant to corrosion, pitting and flaking. The use of stainless steel is recommended but optional.
 - b. Surface textures equivalent to a number 4 finish are not required.
 - c. Welds should be continuous, relatively smooth and free of pits, folds and snags. Where necessary for functional reasons, skip welds may be used. Grinding and polishing of welds is not required.
 - d. Minimum radii of internal angles of less than 135 degrees are not required. However, it is recommended that sharp internal angles be avoided.
 - e. Bolted construction and exposed threads are acceptable on dry lactose applications.